

Xenon Lamp Listing



High performance short arc Xenon lamp solutions

Christie Xenon short arc lamps light up screens around the world and help you provide the best cinema experience to your patrons. To get a true representation of color in any environment requires a truly remarkable light source and the Christie Xenon short arc lamp delivers. The lamps offer stable color temperature, a wide range of power levels and excellent color rendition. Christie understands the

cinema industry. We know our customers personally. With no margin for error, the show must always go on. Christie brings over 75 years of experience, knowledge and value to your cinema business. From concept to completion, Christie is the undisputed leader in creating solutions for your cinema.

CHRISTIE®



The Christie CP Series digital cinema projectors, powered by CDXL Xenon short arc lamps, set new levels of performance for digital cinema technology. Choices in brightness levels and power levels offer flexibility for a variety of screen sizes in existing theater infrastructure.

The use of a CDXL lamp is guaranteed against defect while operating in any Christie CP Series digital cinema projector.



CDXL short arc Xenon lamps

At the heart of Christie's CP Series digital cinema projector line are Christie's CDXL high performance short arc Xenon lamps. These lamps have been optimized for use with the CP Series digital cinema projectors. With increased brightness in the same form factor as standard cinema grade lamps, CDXL lamps provide higher output and brightness in a more cost-efficient package.

Christie CDXL lamp down program for film consoles

Christie's CDXL high performance Xenon lamps are highly efficient and allow you to reduce the lamp size in your film console 1000W from the originally specified lamp while maintaining or improving brightness.

Customer benefits:

- Same or improved brightness
- Up to twice the life expectancy
- Lower operating costs

▲ The DreamWorks® Shrek 4D Adventure is a 3D film like no other using specially designed "Ogre Vision" glasses, motion-controlled seating and Christie's acclaimed high resolution CP2000 DLP Cinema® projectors to project the latest ogre-whelming adventure.

Wavelength diagram

Xenon short arc lamps
Engineered for superior performance in all cinema applications.

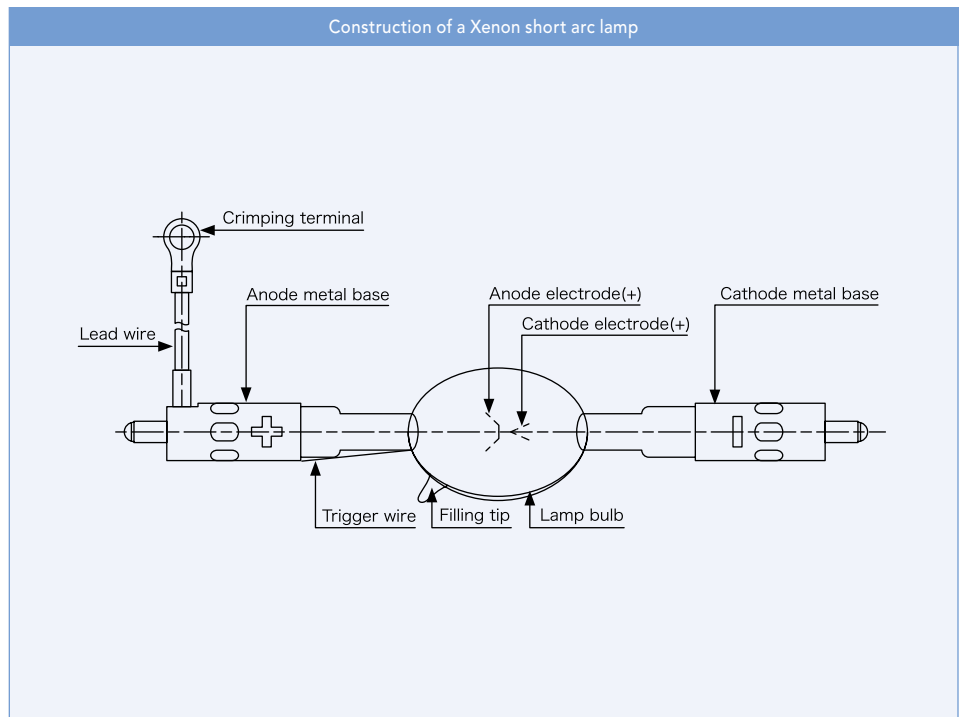
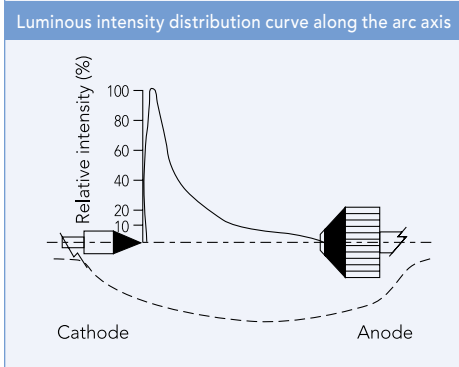
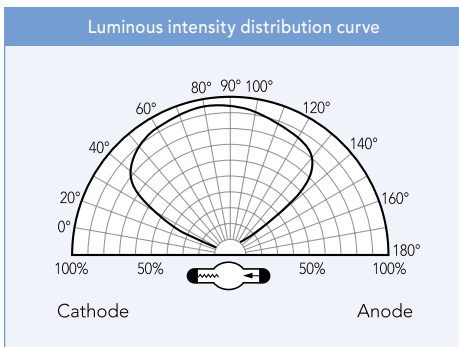
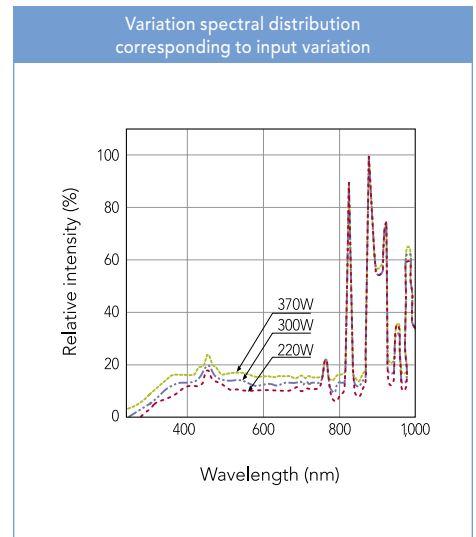
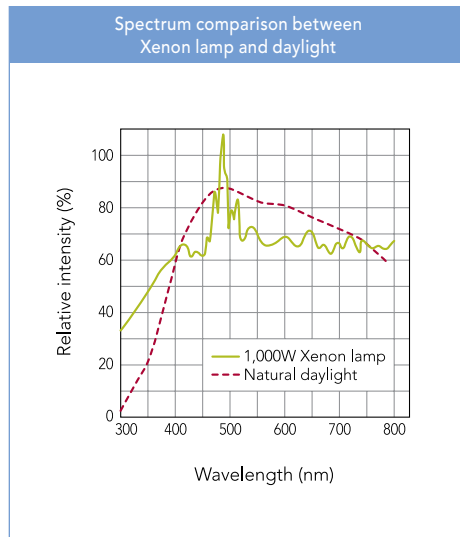
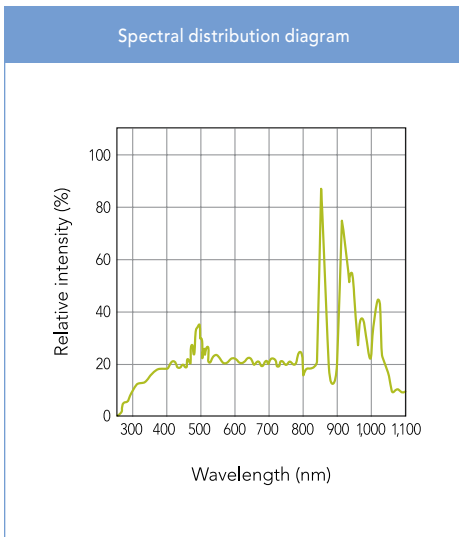

CDXL-20 (003-000598-02)

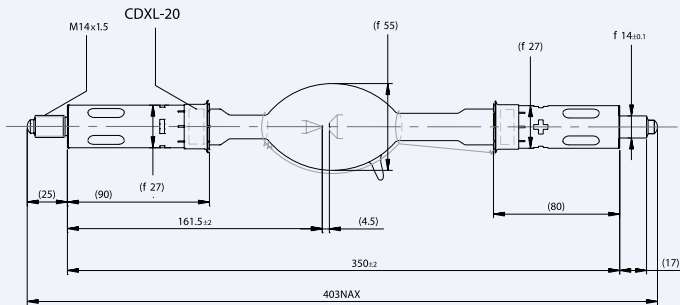

- Improved performance
- Cost-efficient
- Purpose built for cinema applications

Operational information

Lamp	CDXL-20
Average life	3500 hrs
Warranty	100% warranty to 2400 hrs
Performance gain	26%

Technical data

Rated input power	2000W
Rated current	80A
Operating current range	60-85A
Rated voltage	25V
Cold arc gap	4.5mm
Lamp length (L1)	403mm
Lamp length (L2)	350mm
LCL (L3)	161.5mm
Bulb diameter	ø 55mm
Base diameter	ø 27mm
Cathode pin diameter	ø M14 x 1.5mm
Anode pin diameter	ø 14mm
Horizontal	±5°
Base surface temperature	200°C max
Forced air cooling	10 to 13 m/s

CDXL-30 (003-000599-02)

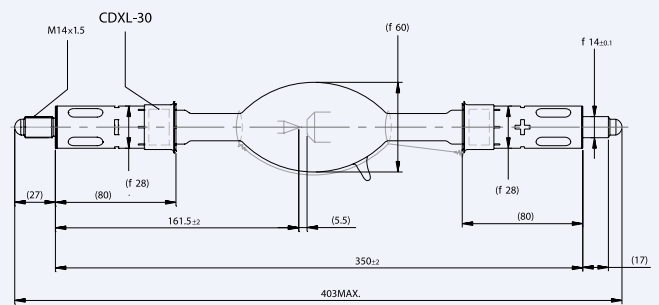

- Improved performance
- Cost-efficient
- Purpose built for cinema applications

Operational information

Lamp	CDXL-30
Average life	2500 hrs
Warranty	100% warranty to 1400 hrs
Performance gain	27%

Technical data

Rated input power	3000W
Rated current	110A
Operating current range	90-120A
Rated voltage	27V
Cold arc gap	5.5mm
Lamp length (L1)	403mm
Lamp length (L2)	350mm
LCL (L3)	161.5mm
Bulb diameter	ø 60mm
Base diameter	ø 28mm
Cathode pin diameter	ø M14 x 1.5mm
Anode pin diameter	ø 14mm
Horizontal	±5°
Base surface temperature	200°C max
Forced air cooling	10 to 13 m/s

CDXL-45 (003-000600-02)

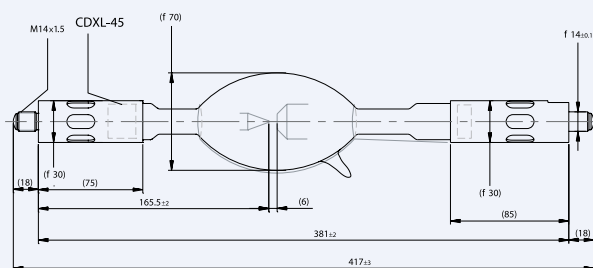

- Improved performance
- Cost-efficient
- Purpose built for cinema applications

Operational information

Lamp	CDXL-45
Average life	1000 hrs
Warranty	100% warranty to 900 hrs
Performance gain	38%

Technical data

Rated input power	4500W
Rated current	145A
Operating current range	95-155A
Rated voltage	31.5V
Cold arc gap	6mm
Lamp length (L1)	417mm
Lamp length (L2)	381mm
LCL (L3)	165.5mm
Bulb diameter	ø 70mm
Base diameter	ø 30mm
Cathode pin diameter	ø M14 x 1.5mm
Anode pin diameter	ø 14mm
Horizontal	±5°
Base surface temperature	200°C max
Forced air cooling	10 to 13 m/s

CDXL-60 (003-000601-02)

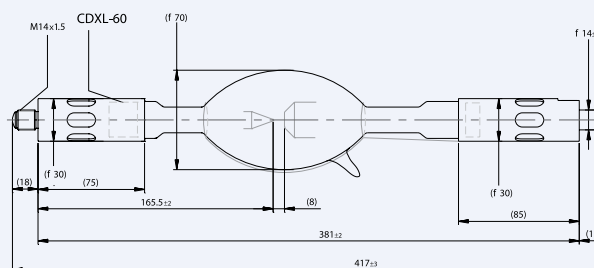

- Improved performance
- Cost-efficient
- Purpose built for cinema applications

Operational information

Lamp	CDXL-60
Average life	900 hrs
Warranty	100% warranty to 600 hrs
Performance gain	11%

Technical data

Rated input power	6000W
Rated current	155A
Operating current range	105-165A
Rated voltage	39V
Cold arc gap	8mm
Lamp length (L1)	417mm
Lamp length (L2)	381mm
LCL (L3)	165.5mm
Bulb diameter	ø 70mm
Base diameter	ø 30mm
Cathode pin diameter	ø M14 x 1.5mm
Anode pin diameter	ø 14mm
Horizontal	±5°
Base surface temperature	200°C max
Forced air cooling	10 to 13 m/s



CDXL-SD Xenon short arc lamps

The new Christie CDXL-SD high performance Xenon lamps are now available for Christie digital cinema projectors. Available in 2kW for the CP2000-M, 3kW for the CP2000-ZX and soon to be available in a 6kW for the CP2000-SB and CP2000XB. The SD series of Xenon were designed specifically for optimum performance in the CP2000 Series projectors in which they operate.

CDXL-20SD (003-001976-01)

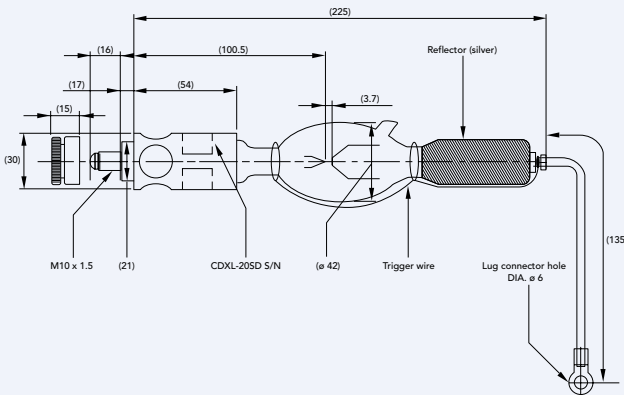

- Improved brightness
- Purpose built for cinema applications

Operational information

Lamp	CDXL-20SD
Average life	see your Christie representative
Warranty	see your Christie representative
Performance gain	n/a

Technical data

Rated input power	2000W
Rated current	75A
Operating current range	70-81A
Rated voltage	26.5V
Cold arc gap	3.7mm
Lamp length (L1)	241mm
Lamp length (L2)	225mm
LCL (L3)	100.5mm
Bulb diameter	ø 42mm
Base diameter	ø 30mm
Cathode pin diameter	ø M10 x 1.5mm
Anode pin diameter	n/a
Horizontal	±5°
Base surface temperature	200°C max
Forced air cooling	10 to 13 m/s

CDXL-30SD (003-001165-01)

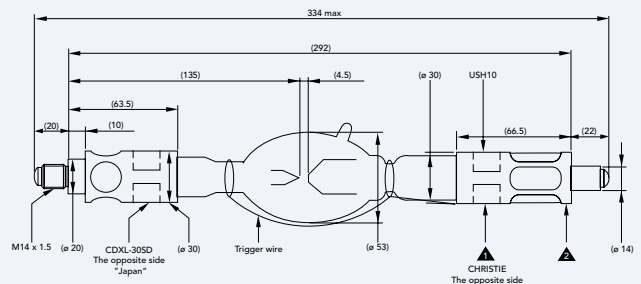

- Improved brightness
- Purpose built for cinema applications

Operational information

Lamp	CDXL-30SD
Average life	900 hrs
Warranty	0-300 – 100% 301-750 – Pro-rated
Performance gain	30%

Technical data

Rated input power	3000W
Rated current	100A
Operating current range	93-107A
Rated voltage	30V
Cold arc gap	4.5mm
Lamp length (L1)	334mm
Lamp length (L2)	292mm
LCL (L3)	135mm
Bulb diameter	ø 53mm
Base diameter	ø 30mm
Cathode pin diameter	ø M14 x 1.5mm
Anode pin diameter	ø 14mm
Horizontal	±5°
Base surface temperature	200°C max
Forced air cooling	10 to 13 m/s

▼ Hoyts Cinema, Australia

CDXL-60SD (See Christie Rep – available soon)

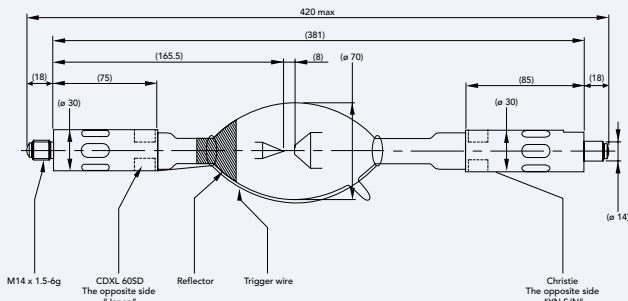

- Improved brightness
- Purpose built for cinema applications

Operational information

Lamp	CDXL-60SD
Technical data	
Rated input power	7000W
Rated current	170A
Operating current range	105-170A
Rated voltage	40V
Cold arc gap	8mm
Lamp length (L1)	420mm
Lamp length (L2)	381mm
LCL (L3)	165.5mm
Bulb diameter	ø 70mm
Base diameter	ø 30mm
Cathode pin diameter	ø M14 x 1.5mm
Anode pin diameter	ø 14mm
Horizontal	±5°
Base surface temperature	200°C max
Forced air cooling	10 to 13 m/s



Christie understands the cinema industry. We know our customers personally. With no margin for error, the show must always go on and our CXL short arc Xenon lamps are integral to that promise. Christie brings over 75 years of experience, knowledge and value to your cinema business. From concept to completion, Christie is the undisputed leader in creating solutions for your cinema.

	Rated input power	Rated current	Operating current range	Rated voltage	Cold arc gap	Overall lamp length	Lamp length between connector faces	Lamp length from rear connector face to arc center	Bulb diameter	Cathode pin diameter	Anode pin diameter	Cables included	Vertical tolerance	Horizontal tolerance
	W	A	ADC	VDC	mm	mm	mm	mm	mm	mm	mm	mm	±°	±°
CXL-10	1000	45	35 - 50	20	5.0	330	275	125	45	M14XP1.5	14	No	N/A	15
CXL-10S	1000	50	30 - 55	20	4.2	235	205	96.5	40	5/16-18UNC	11	No	N/A	15
CXL-10SC	1000	50	30 - 55	20	4.2	236	222	96.5	40	5/16-18UNC	N/A	Anode	N/A	15
CXL-16SC	1430	65	45 - 70	22	4.0	236	222	96.5	48	5/16-18UNC	N/A	Anode	N/A	15
CXL-16S	1430	65	45 - 70	22	4.0	235	205	96.5	48	5/16-18UNC	11	No	N/A	15
CXL-1600A	1600	65	45 - 70	24	4.8	365	320	145	55	12	10	Anode	30	N/A
CXL-20*	2000	80	60 - 85	25	6.0	375	320	145	55	M14XP1.5	14	No	15	15
CXL-20SC	2000	80	50 - 85	25	6.0	342	302	147	60	7.9	9.4	Anode	30	30
CXL-20R	2000	70	50 - 85	29	6.0	370	320	145	55	12	10	Both	30	30
CXL-25*	2500	90	70 - 95	24	7.0	403	350	165	60	M14XP1.5	14	No	15	15
CXL-2500LC	2500	83	60 - 85	27	7.0	433	380	171	57	14	13	Anode	30	30
CXL-25SC	2500	90	70 - 100	28	6.0	345	300	147	60	7.9	9.4	Anode	15	15
CXL-30*	3000	100	80 - 110	27	7.0	403	350	165	60	M14XP1.5	14	N/A	N/A	15
CXL-30SC	3000	100	60 - 110	30	6.5	342	302	147	60	7.9	9.5	Anode	30	30
CXL-30R	3000	100	60 - 100	30	7.0	428	382	171	70	14	13	Both	30	30
CXL-40*	4000	130	100 - 140	29	7.0	433	380	170	70	M14XP1.5	14	No	N/A	15
CXL-40SC	4000	135	80 - 150	29	7.0	410	370	174.5	70	7.9	9.4	Anode	N/A	15
CXL-4200A	4200	140	100 - 150	30	7.0	428	380	170	70	14	13	Both	N/A	15
CXL-45*	4500	150	100 - 160	30	8.0	433	380	170	80	M14XP1.5	14	No	N/A	15
CXL-50SC	5000	140	110 - 150	35	8.0	410	370	171	70	7.85	9.4	Anode	N/A	15
CXL-60*	6000	160	110 - 170	37	9.0	417	381	170	80	M14XP1.5	14	No	N/A	15
CXL-60SC	6000	160	110 - 170	37	9.0	433	392	176	80	7.85	9.4	Anode	15	15
CXL-70	7000	160	110 - 170	43	11.0	417	381	170	80	M14XP1.5	14	No	N/A	15
CXL-70SC	7000	160	110 - 170	43	11.0	433	392	176	80	7.85	9.4	Anode	15	15

*Christie Core Lamps

Product reference notes and suffixes

- Consult factory for proper application
- A – with anode cable
- S – short lamp length/threaded tip on cathode end and 11mm pin on anode end/no cables
- SC – short lamp length/8mm cathode and 9.5mm anode pins/with anode cable
- LC – longer lamp length/lug type connector/14mm pins/with anode cable
- R – longer lamp length/with both cables
- No suffix – threaded tip on cathode end and 14mm pin on anode end/no cables

Manufacturer's cross reference

Christie Xenolite Lamps (Model numbers subject to change without notice)

Wattage	Model number	OSRAM	LTI
1000	CXL-10	XBO 1000W/HTP OFR	LTIX 1000W-HTP
1000	CXL-10S	XBO 1000W/HS OFR	LTIX 1000W-HS
1000	CXL-10SC	XBO 1000W/HSC OFR	LTIX 1000W-HSC
1600	CXL-16S	XBO 1600W/HS OFR	LTIX 1600W-HSCH
1600	CXL-16SC	XBO 1600W/HSC OFR	LTIX 1600W-HSCCH
2000	CXL-20	XBO 2000W/HTP OFR	LTIX 2000W-HTPCH
2000	CXL-20R	XBO 2000W/H OFR	LTIX 2000W-HCH
2000	CXL-20SC	XBO 2000W/HS OFR	LTIX 2000W-HSXH
2500	CXL-25	NONE	NONE
2500	CXL-25SC	XBO 2500W/HS OFR	LTIX 2500W-HSCH
3000	CXL-30	XBO 3000W/HTP OFR	LTIX 3000W-HTPCH
3000	CXL-30R	XBO 3000W/H OFR	LTIX 3000W-HCH
3000	CXL-30SC	XBO 3000W/HS OFR	LTIX 3000W-HSXH
4000	CXL-40	XBO 4000W/HTP OFR	LTIX 4000W-HTPCH
4000	CXL-40SC	XBO 4000W/HS OFR	LTIX 4500W-HSCH
4500	CXL-45	NONE	NONE
5000	CXL-50SC	NONE	L5000W-HS
6000	CXL-60	NONE	LTIX 6000W-HTP
6000	CXL-60SC	NONE	LTIX 6002W-HS
7000	CXL-70	NONE	NONE
7000	CXL-70SC	XBO 7000W/HS OFR	LTIX 7000W-HSCH
1600	CXL-1600A	XBO 1600W/CA OFR	LTIX 1600W-H
2000	CXL-20R	XBO 2000W/H OFR	LTIX 2000W-H
2500	CXL-2500 (LC)	XBO 2500W OFR	LTIX 2500W-H
3000	CXL-30R	XBO 300W/H OFR	LTIX 3000W-H
4000	CXL-4200	XBO 4000W OFR	LTIX 4200W-HC
4200	CXL-4200A	XBO 4200W/CA OFR	LTIX 4200W-H







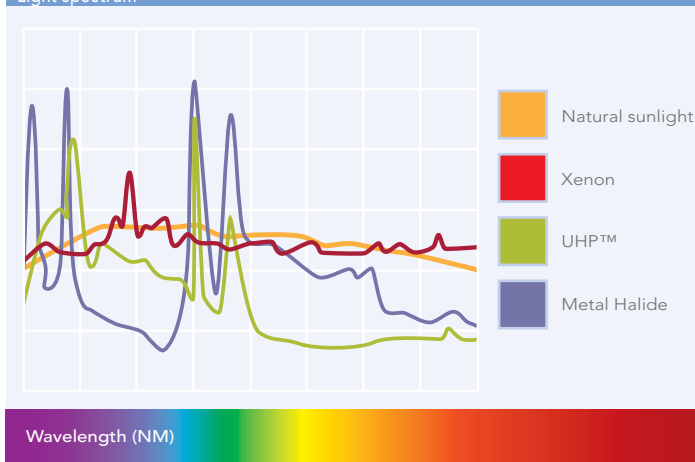

Champion Xenolite lamp warranty





Model CXL	Full credit HRS
-10S, -10SC, -16S, -16SC	2000
-10, -20, -20R, -20SC	2400
-30, -30R, -30SC	1500
-25, -25SC	1500
-40, -40SC, -45	1200
-50SC	1000
-60, -60SC	600
-70, -70SC	500
900A, 1600A	2400
2500LC	1800
4200A	1200

Light spectrum



Warning

-  Do not operate the lamp in close proximity to paper, cloth or other combustible material, nor cover it with such materials, even immediately after it is turned off. Otherwise it could cause a fire.
-  As the lamp is filled with high pressure Xenon gas, do not hit the lamp against anything, apply excessive stress or scratch the lamp. Otherwise it could cause an injury if it bursts.
-  The lamp must be operated in a splinter-scatter-proof lamp house. Do not open the lamp house while the lamp is operating or immediately after it is turned off. Otherwise it could cause an injury if it bursts.
-  Do not touch the lamp while it is operating or immediately after it is turned off because it is extremely hot. Otherwise it could cause a burn.
-  Do not operate the lamp in an atmosphere containing an inflammable substance, such as gasoline, spray containing volatiles, thinner, lacquer or dust. Otherwise it could cause a fire or an explosion.
-  As the lamp is filled with high pressure Xenon gas, it must be kept in the provided protective case when transporting, storing or disposing. Otherwise it could cause an injury, if it bursts.
-  The lamp that has been used for the rated service life is more likely to break and burst because of the deteriorated glass condition. Therefore, follow the instructions above for replacement for replacement and disposal of the used lamp. Otherwise it could cause injury if it bursts.
-  Wear a protective mask, protective gloves and a thick long-sleeved shirt, when the lamp is handled or installed and removed to/from the lamp house.

- The protective mask which covers the carotid, must be made with thicker than 2mm polycarbonate or another material with same strength or more.
- Gloves and a thick long-sleeved shirt must be made with ripping-proof and piercing-proof material like aramid fiber. Otherwise it could cause an injury if the lamp bursts.
-  Operate the lamp in the position indicated in the column of the burning position in this certificate. Otherwise it could cause overheating of the lamp house, lamp breakage or short lamp life.
-  Thoroughly ventilate the area or the room when operating the lamp in an oxygen atmosphere (in air), except in the case of ozone-free lamps. If ozone is inhaled, it could cause headaches, nausea, dizziness, etc.
-  Turn off the electrical power before installing, removing or cleaning the lamp house. Otherwise it could cause electrical shock.
-  During operation the lamp emits intense UV radiation which is harmful to the eyes and skin. Do not look directly or indirectly at the operating lamp. Otherwise it could cause eye aches or eyesight problems.
-  Do not directly or indirectly expose your skin to the lamp light, otherwise it could cause inflammation of the skin.

Important operation notes

- The lamp must be operated under the specified use conditions such as lamp current, lamp voltage and cooling condition.
- Keep the lamp base temperature below 200°C or maximum temperature if specified by following cooling conditions designated.

Caution

Handling

- When the lamp is soiled with fingerprints by touching glass envelope with bare hand or dust, clean it with alcohol-soaked cloth. Otherwise it could burst or shorten lamp life.
- Do not subject the lamp to vibration or shock, otherwise, it could burst or shorten lamp life.

Installation

- Install the lamp in the correct polarity. Otherwise it could burst, cause overheating of the lamp house or shorten lamp life.
- Do not apply excessive stress such as twisting or bending when installing the lamp, otherwise it could cause an injury if it bursts.
- Do not use any tools to tighten connections when fixing the lamp, use only hands, otherwise it could cause breakage.
- Fix the lamp and its lead wire firmly to the terminals. Before fixing, make sure that there is no rust, burning or discoloration where electrical connections are made between the lamp and the lamp house, otherwise it could cause overheating by poor electrical connection.
- Install the lamp with the protective cover. Be sure to remove the protective cover from the lamp after installation.
- Cover the lamp with the protective cover before removing the lamp from the lamp house, otherwise it could cause an injury if the lamp bursts.

Operation

- Do not open the lamp house for at least ten (10) minutes after the lamp is turned off, otherwise it could cause an injury if it bursts.

- Remove the lamp from the lamp house after making sure it has been turned off for more than 15 minutes and the lamp and lamp house have cooled down, otherwise, it could cause an injury or burn if the lamp bursts.

Use a suitable lamp house and power supply (ballast). Operate a lamp in the range of wattage designated.

Storage

Store the lamp under the following conditions:
Temperature: – 25–65°C Humidity: 20–95%RH,
without condensation

Disposal

- The used lamp must be kept in the provided protective case until disposal by breaking the glass part. Otherwise it could cause injury.
- The lamp is filled with high pressure Xenon gas. Disposal without breaking the glass part may result in lamp burst. Follow the instructions below to prevent harmful repercussions:

WEAR A PROTECTIVE MASK, PROTECTIVE GLOVES AND A LONG SLEEVED SHIRT WHEN HANDLING THE LAMP.

1. The used lamp must be kept in the provided protective case; the case must be securely locked by the metallic stopper.
2. Place the used lamp in the protective case into the provided box. Firmly attach the tape of the paper case to make certain the case will not open if the lamp is dropped.
3. From about one (1) meter in height, drop the provided box, with the lamp and protective case inside, onto a hard floor.
4. Shake the box to determine if the lamp is broken.
5. Dispose of as industrial waste. Dispose separately where metal and glass must be disposed of separately.

Warranty hours

Effective Jan 1, 2006

Lamps purchased after January 1, 2006 will be subject to the above warranty life hours and the following standard terms and conditions*.

* Credit is subject to the following conditions or exclusions:

1. **DAMAGE IN SHIPMENT IS NOT COVERED BY WARRANTY.** Bulbs must be inspected upon arrival. If damaged, a claim must be filed immediately with the carrier.
2. Defective bulb (all metal parts if bulb is shattered) must be returned to Christie, freight prepaid and insured for the amount of anticipated credit, together with completed warranty form.
3. Bulb must have been operated with the correct polarity, not below rated minimum current, nor above maximum rated power, in accordance with applicable air cooling requirements and other operating conditions.
4. If the bulb is operated with a spherical reflector, the reflected cathode hot spot must not be superimposed on either of the bulb's electrodes.
5. **INSPECTION AND TEST AT CHRISTIE MUST VERIFY CLAIM.**
6. Christie shall not be liable for any consequential damage other than **REFLECTOR** under CXL lamp types or **REFLECTOR, UV FILTER AND INTEGRATOR**, if used in CP2000 series projectors.
7. Any credit due is based on the Christie net selling price and warranty applicable at time of purchase of the defective bulb and issued to the original purchaser. New, unused lamps may be returned only if within 2 years from original date of purchase. Lamps over 5 years old will not be covered under warranty regardless of hours used.
8. In the event of a warranty dispute, the final decision rests solely with Christie.



Corporate offices

USA – Cypress
ph: 714-236-8610
Canada – Kitchener
ph: 519-744-8005

Worldwide offices

United Kingdom
ph: +44 118 977 8000
Germany
ph: +49 2161 664540
France
ph: +33 (0) 1 41 21 44 04

Hungary/Eastern Europe
ph: +36 (0) 1 47 48 100
Singapore
ph: +65 6877 8737
India
ph: +91 80 4146 8940

Shanghai
ph: +86 21 6278 7708
Beijing
ph: +86 10 6561 0240

Korea
ph: +82 2 702 1601
Japan
ph: +81 3 3599 7481



For the most current specification information, please visit www.christiedigital.com



Copyright 2008 Christie Digital Systems, Inc. All rights reserved. All brand names and product names are trademarks, registered trademarks or tradenames of their respective holders. Canadian manufacturing facility is ISO 9001 and 14001 certified. Performance specifications are typical. Due to constant research, specifications are subject to change without notice. Printed in Canada on recycled paper. 2394 Oct 08

CHRISTIE®